



OUTPUT SPECIFICATION:

Output 1 & 2	0 to 10V DC
Response Type	<150ms
Output Impedance	≤500Ω
Transmitter Supply	24V DC

POWER SUPPLY:

Auxiliary Voltage	24V DC
Power Consumption (VA Rating)	3VA @24V DC

ISOLATION:

Isolation Type	Optical - 3 way
Isolation between supply, input & Output	At least 1.5KV AC for 1 min

FEATURES

- 1.5KV isolation between supply, input & output
- Linearized O/P
- Zero & span correction facility through trim port
- Fast Response time <150ms
- Din Rail Mounting

MECHANICAL INSTALLATION

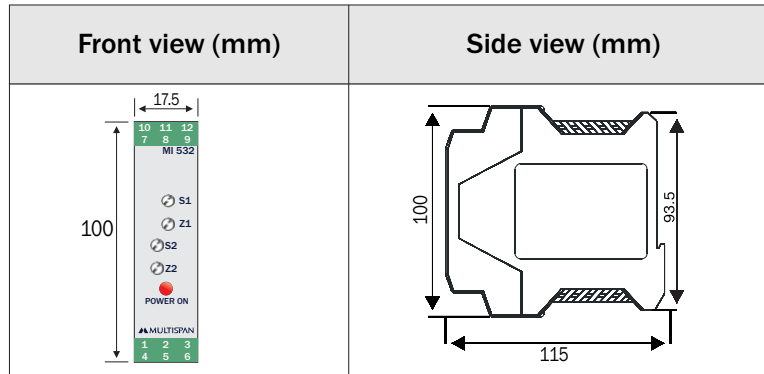

TECHNICAL SPECIFICATION

INPUT SPECIFICATION:

Input	4-20mA DC
Input Impedance	≥100KΩ
CMRR	>120dp (Typical)
Temperature Co-efficient	<100 PPM

DIMENSION:

Size (HxWxD) mm	100 X 17.5 X 115
-----------------	------------------

TERMINAL CONNECTION

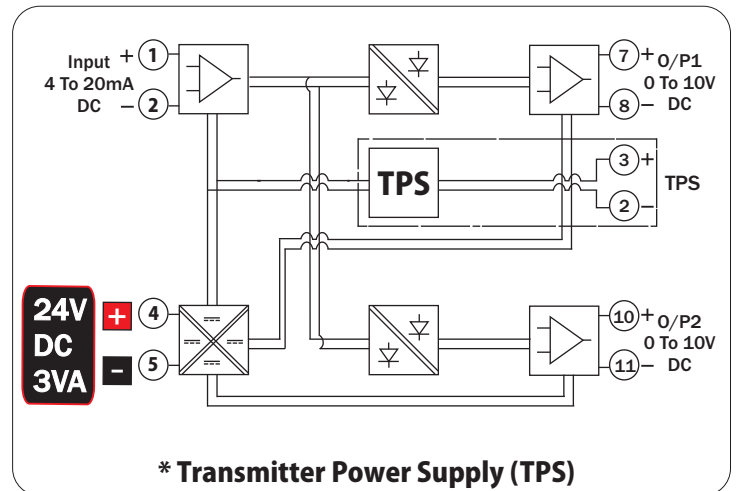



SAFETY PRECAUTION

All safety related codifications, symbols and instructions that appear in this operating manual or on the equipment must be strictly followed to ensure the safety of the operating personnel as well as the instrument.

If all the equipment is not handled in a manner specified by the manufacturer, it might impair the protection provided by the equipment.



Read complete instructions prior to installation and operation of the unit.



WARNING : Risk of electric shock.

MECHANICAL INSTALLATION GUIDELINES

- 1) To install the instrument on a DIN rail, raise the clamp at the back of the instrument and place it on the rail. Now release the clamp, so the instrument fits on the DIN rail.
- 2) Ensure proper fitting of the instrument by pulling it outwards.
- 3) To remove the instrument raise the clamp to release it from the DIN rail.
- 4) The equipment in its installed state must not come in close proximity to any heating source, caustic vapors, oil steam, or other unwanted process byproducts.
- 5) Do not connect anything to unused terminals.

MAINTENANCE

1. The equipment should be cleaned regularly to avoid blockage of ventilating parts.
2. Clean the equipment with a clean soft cloth. Do not use isopropyl alcohol or any other cleaning agent.
3. Fusible resistor must not be replaced by operator.

WARNING GUIDELINES



WARNING : Risk of electric shock.

1. To prevent the risk of electric shock, power supply to the equipment must be kept OFF while doing the wiring arrangement. Do not touch the terminals while power is being supplied.
2. To reduce electro magnetic interference, use wire with adequate rating and twists of the same of equal size shall be made with shortest connection.
3. Cable used for connection to power source, must have a cross section of 1mm or greater. These wires should have insulation capacity made of at least 1.5kV.
4. A better anti-noise effect can be expected by using standard power supply cable for the instrument.

INSTALLATION GUIDELINES

- 1) Do not allow pieces of metal, wire clippings, or fine metallic fillings from installation to enter the product or else it may lead to a safety hazard that may in turn endanger life or cause electrical shock to the operator.
- 2) Circuit breaker or mains switch must be installed between power source and supply terminal to facilitate power 'ON' or 'OFF' function. However this mains switch or circuit breaker must be installed at convenient place normally accessible to the operator.
- 3) Use and store the instrument within the specified ambient temperature and humidity ranges as mentioned in this manual.