

**MULTISPAN** 3 Phase VAF Meter AVF-133



**DISPLAY, KEY & LED**

Display	3 Digit , 6 Line 7 Seg. 0.36" Red LED
Key	Scroll, Set, Inc, Dec
LED Indication	A , KA , VLL , VLN , Avg, PS, Hz

**ENVIRONMENTAL CONDITION**

Working Temperature	0 to 55 °C
Storage Temperature	0 to 55 °C
Relative Humidity	95 % RH Non - Condensing
Protection Level	IP-65 (Front side As per IS/IEC 60529 : 2001)

**DIMENSION**

Size (mm)	96 (H) x 96 (W) x 54 (D) mm
Panel Cutout	92 (H) x 92 (W) mm

**TERMINAL CONNECTION**

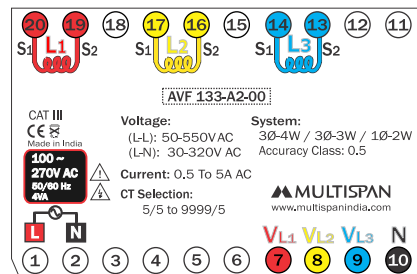

Please Refer page-2 for wiring connection

**KEY OPERATION**

FUNCTION	SYMBOL
To enter in parameter setting mode	SET + ^
<b>Operator mode:</b> To change page	^
<b>Parameter setting mode:</b> To increment value	^
To decrement value in parameter setting mode.	v
To set the parameter value and to be save and exit from menu.	SET
Scroll & hold for 5 Sec	⊙

**NOTE :**

1) If Phase sequence is not correct then PS LED will turn ON.

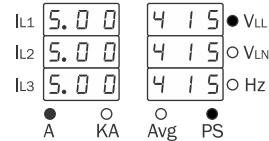

2) If Current exceed 999Amp, KA LED will turn ON. Display will be as show below.

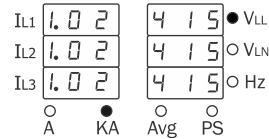

3) In Load hour page blinking LDH is indicating that load hour is incrementing.

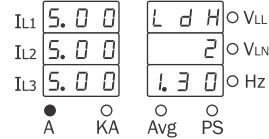

Actual load hour = 21 hours 30 minutes.

**PARAMETER SETTING**

Press (SET) key & (^) key together for C.T ratio selection & network connection

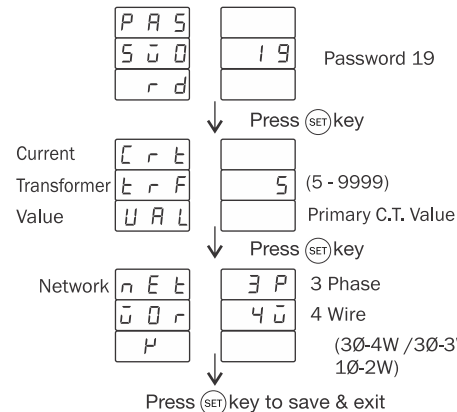

Press (SET) key & (^) key together for reset load hour

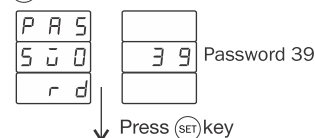

To be continued

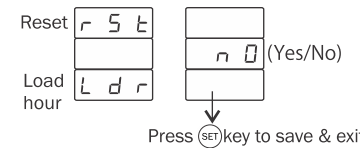

Press (SET) key & (^) key together for load hour & RPM.

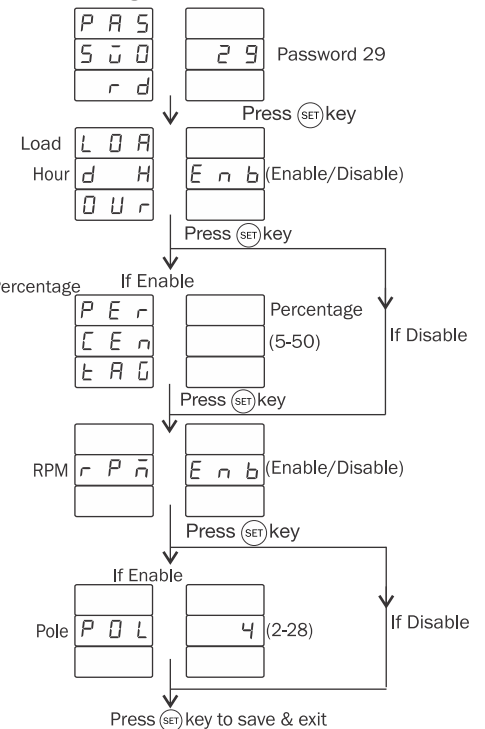

**1Ø-2W NETWORK CONNECTION**

1) Average Page :-

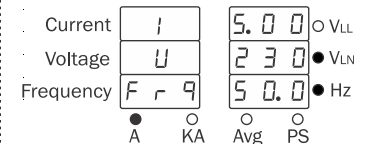

2) Load hour & RPM Page :-

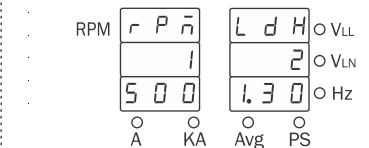

**TECHNICAL SPECIFICATION**

**FEATURES**

- Separate display for Amp indication
- Wiring System: 3Ø-4W, 3Ø-3W, 1Ø-2W
- Load Hour , RPM, Phase sequence by LED indication

**INPUT**

Voltage AC	
Direct Voltage AC	30 to 300V (L - N) 50 to 520V (L - L)
Burden	< 0.2 VA
Current AC	
Primary CT Ratio	5 to 9999 Selectable
Secondary Current Ac	0.1 To 5 Amp
Burden	< 0.2 VA
Overload	Up to 6A Continuous
Frequency	45.0 to 65.0 HZ

**CALCULATED PARAMETERS**

Voltage	VLL , VLN , Avg
Current	All Phase Amp, Avg Amp
Frequency	System Frequency
Phase Sequence	Indication
Load Hour	Up to 9999 Hr 59 min

**ACCURACY**

Class 0.5 (Standard)
----------------------

**AUXILIARY POWER SUPPLY**

Power Supply	100 to 270V AC, 50/60Hz
Burden	4VA

### 30-4W NETWORK CONNECTION

#### 1) V<sub>LL</sub> Page :-

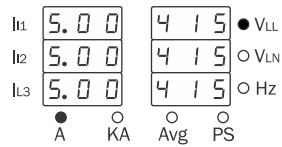

#### 2) V<sub>LN</sub> Page :-

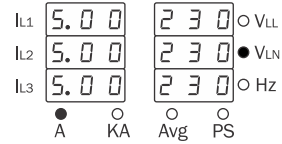

#### 3) Frequency Page :-

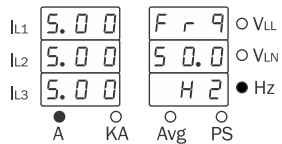

#### 4) Average Page (VLN),(VLL),(AMP) :-

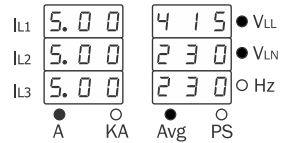

#### 5) Load Hour Page :-

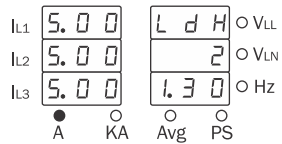

#### 6) RPM Page:-

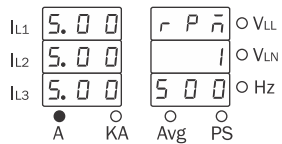

### 30-3W NETWORK CONNECTION

#### 1) V<sub>LL</sub> Page :-

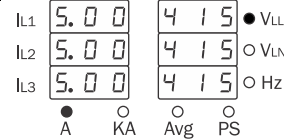

#### 2) Frequency Page :-

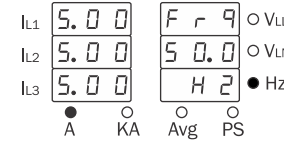

#### 3) Average Page(VLL), (AMP) :-

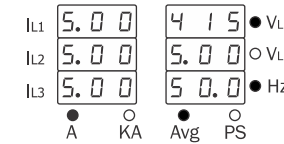

#### 4) Load Hour page :-

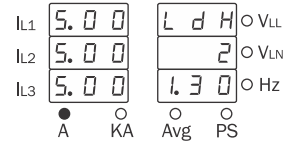

#### 5) RPM Page:-

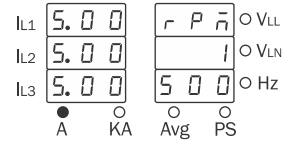

### INSTALLATION GUIDELINES

1. This equipment, being built-in-type, normally becomes a part of main control panel and in such case the terminals do not remain accessible to the end user after installation and internal wiring.
2. Do not allow pieces of metal, wire clippings, or fine metallic fillings from installation to enter the product or else it may lead to a safety hazard that may in turn endanger life or cause electrical shock to the operator.
3. Circuit breaker or mains switch must be installed between power source and supply terminal to facilitate power 'ON' or 'OFF' function. However this mains switch or circuit breaker must be installed at convenient place normally accessible to the operator.
4. Use and store the instrument within the specified ambient temperature and humidity ranges as mentioned in this manual.

### MECHANICAL INSTALLATION GUIDELINES

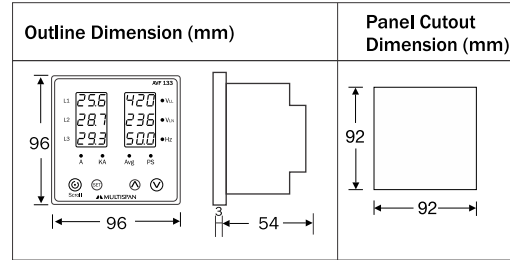

1. Prepare the panel cutout with proper dimensions as show above.
2. Fit the unit into the panel with the help of clamp given.
3. The equipment in its installed state must not come in close proximity to any heating source, caustic vapors, oils steam, or other unwanted process by products.
4. Use the specified size of crimp terminal (M3.5 screws) to wire the terminal block. Tightening the screws on the terminal block using the tightening torque of the range of 1.2 N.m.
5. Do not connect anything to unused terminals.

### WARNING GUIDELINES

**WARNING : Risk of electric shock.**

1. To prevent the risk of electric shock power supply to the equipment must be kept OFF while doing the wiring arrangement. Do not touch the terminals while power is being supplied.
2. To reduce electro magnetic interference, use wire with adequate rating and twists of the same of equal size shall be made with shortest connection.
3. Cable used for connection to power source, must have a cross section of 1mm or greater. These wires should have insulations capacity made of at least 1.5kV.
4. A better anti-noise effect can be expected by using standard power supply cable for the instrument.

### SAFETY PRECAUTION

All safety related codifications, symbols and instructions that appear in this operating manual or on the equipment must be strictly followed to ensure the safety of the operating personnel as well as the instrument.

If all the equipment is not handled in a manner specified by the manufacturer, it might impair the protection provided by the equipment.

Read complete instructions prior to installation and operation of the unit.

**WARNING : Risk of electric shock.**

### MAINTENANCE

1. The equipment should be cleaned regularly to avoid blockage of ventilating parts.
2. Clean the equipment with a clean soft cloth, Do not use isopropyl alcohol or any other cleaning agent.
3. Fusible resistor must not be replaced by operator.

### WIRING DIAGRAM

#### 3 Phase - 4Wire

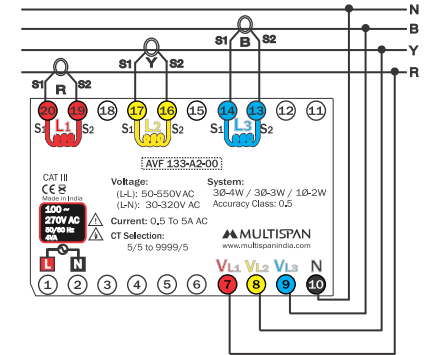

#### 3 Phase - 3Wire

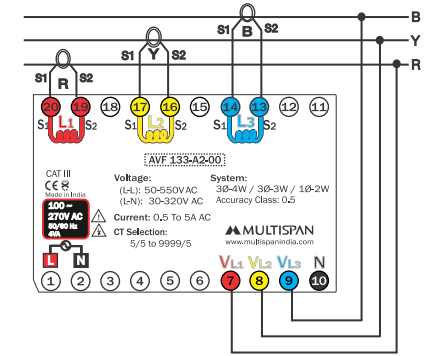

#### 1 Phase - 2Wire

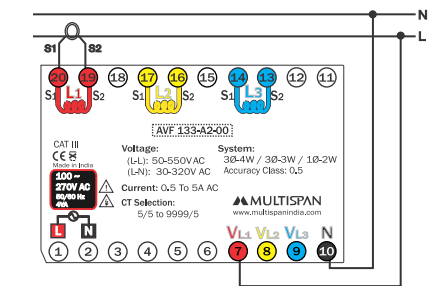

#### Note:

Specifications are subject to change, since development is a continuous process. So for more updated operating information and Support. Please contact our Helpline: +91-9081078683/81 or Email at [service@multispandia.com](mailto:service@multispandia.com) Ver:2.201