

User Manual

## RISH Clamp 300A / 1000A AC-DC

True RMS Digital Clamp meter

---

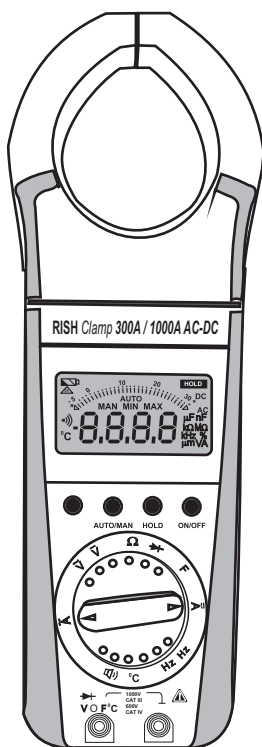

---

REV A :19/03/2012



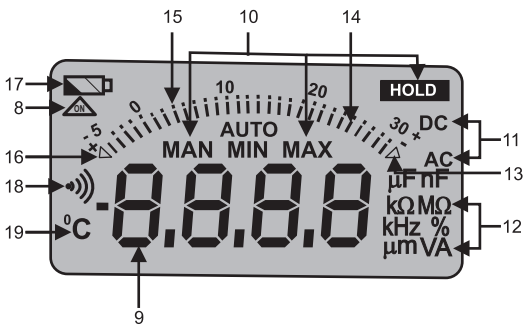
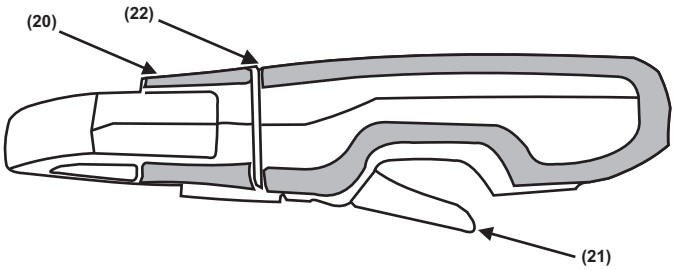
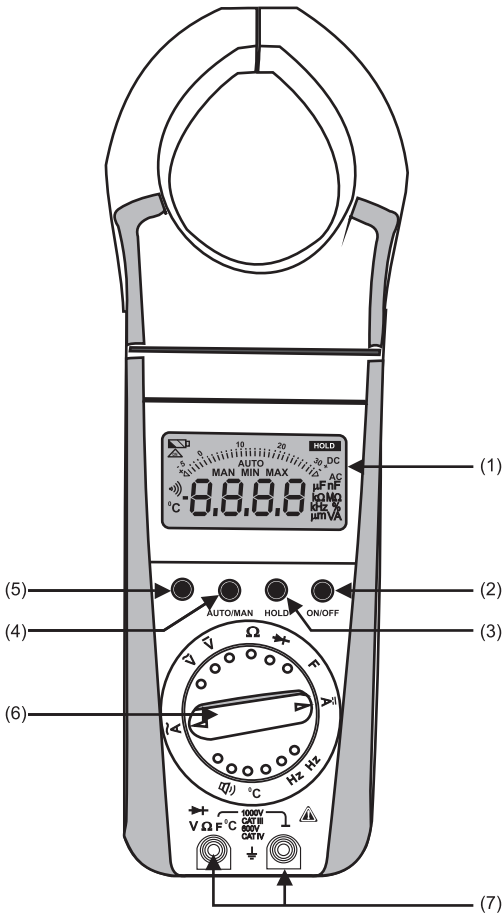

- |   |   |
|---|---|
| (1) Liquid crystal display  | (11) Display for the selected function                |
| (2) ON/OFF pushbutton   | (12) Display for the unit of measured quantity        |
| (3) Pushbutton for data hold and MIN/MAX storage functions              | (13) Over range indication for positive analog range. |
| (4) Pushbutton for manual range selection                               | (14) Pointer for analog indication.                   |
| (5) Multi function pushbutton   | (15) Scale for analog indication                      |
| (6) Function selector switch.   | (16) Over range indication for negative analog range. |
| (7) Terminal sockets  | (17) Low battery indication.                          |
| (8) Symbol for "CONTINUOUSLY ON"  | (18) Buzzer indication                                |
| (9) Display for digits, decimal point and polarity                      | (19) Display °C for temperature measurement range.    |
| (10) Display for manual range selection, data HOLD and MIN/MAX storage. | (20) Rotary mechanism for clamp jaws.                 |
|   | (21) Safe trigger mechanism.                          |
|   | (22) Limit of safe access for hand held.              |

<b>Contents</b>	<b>Page</b>
1. Introduction .....	2
2. Safety features and safety precautions .....	2
3. Switching the Clampmeter "ON" .....	3
4. Function and range selection .....	4
4.1 Autoranging .....	4
4.2 Manual range selection .....	4
5. Liquid crystal display .....	5
5.1 Digital display .....	5
5.2 Analog indication .....	5
5.3 Backlit .....	5
6. Data "HOLD" Facility .....	6
7. Minimum value and maximum value "MIN/MAX storage facility. ....	6
8. Voltage measurement .....	9
8.1 Voltage measurement on electrical system upto 1000V with the KS30 measuring adapter .....	9
9. Resistance measurement .....	11
10. Diode test and continuity test .....	11
11. Temperature measurement .....	12
12. Capacitance measurement .....	12
13. Frequency measurement .....	13
14. Duty cycle measurement .....	13
15. Current measurement .....	14
16. Empty Positions .....	16
17. Specifications .....	17
18. Maintenance .....	21
18.1 Battery .....	21
18.2 Periodic Check-up .....	22
19. Servicing .....	22

## 1. Introduction:

Thank you very much for selecting Clamp Meter.

We are leading manufacturer of Electrical and Electronics state-of-art measuring instruments.

These clamp meters are manufactured as per IS 13875 and DIN 43751.

## 2. Safety features and safety precautions

You have chosen a Clamp meter which provides you a very high degree of safety. The digital clamp meter 300A/1000A manufactured and tested in compliance with the safety standard IEC 61010-1:2010.

In case of incorrect use or careless handling, the safety of both user and clamp meter is not assured.

**For proper use and safe handling, it is absolutely necessary to read and understand the operating instructions before using the clamp meter.**

**Please note the following safety precautions:**

- Operators must use individual protective equipment if hazardous live parts of installation could be accessible.
- Keep hands/fingers behind the edge that separates rotating jaws with hand held part(22). This is the limits of the hand held part during measurement.
- The clamp meter must be operated only by persons who understand the danger of shock hazards and are aware of the necessary safety precautions. Shock hazards exist wherever voltages of more than 30V (TRMS) are present.
- Do not work alone in shock hazardous environment while carrying out measurement.
- The maximum permissible voltage between any of the terminal sockets (7) and ground is 1000V
- Take into account that unexpected voltages can occur on device under test (e.g. defective instrument). For example, capacitors may be charged to a dangerously high voltage.
- Verify that the test leads are in good condition, e.g. no cracked insulation, no open circuits in the leads or connectors.
- This clamp meter must not be used for measurements on circuits with corona discharge (high voltage).
- Be particularly careful when measuring on HF circuits. Dangerous composite voltages may exist there.
- Measurements under moist environmental conditions are not permitted.
- Do not overload the measuring ranges beyond their allowable capacities. Limit values are given in specifications. Ref. Chapter 16.
- For safe voltage measurements in power systems upto 1000V we recommend the KS30 measuring adapter, which is available as an accessory Its internal resistance limits the measuring current in the case of overvoltage, in correct operation and safely suppresses sparking from spark gap. Also refer to Section "8.1 Voltage measurement on electrical systems up to 1000V with KS30 measuring adapter".
- Please verify the performance of clamp meter after repairing of the meter, before using it for actual measurement.
- Do not use the clamp meter if obvious wear in jaw opening is visible.
- Protection provided by the digital clamp meter may be impaired if the clamp meter is not used in a manner specified in this user manual.

## Meaning of categories and their significance per IEC 61010-1



**CAT I:** Measurements in electrical circuits which are not directly connected to the mains: for example electrical systems in motor vehicles and aircraft, batteries etc. circuits

**CAT II:** Measurements in electrical which are electrically connected to the low-voltage mains: with plugs, e.g. at home, in the office or laboratory etc.

**CAT III:** Measurements in building installations, stationary power consumers, distributor terminals, devices connected permanently to the distributor

**CAT IV:** Measurements at power sources for low-voltage installations, meters, mains terminals, primary over voltage protection devices.

### Meaning of the symbols on the device

	Warning of a danger point (Attention, refer to the user manual)
	Earth (ground) terminal.
	Double or reinforced insulation
<b>CAT III / IV</b>	Instrument for over voltage category III OR IV

### Meaning of the acoustic signals

- 1) Intermittent acoustic signal: Voltage limit exceeded; for Voltage > 1000 V
- 2) Intermittent acoustic signal: Current limit exceeded; for Current > 1100 A

### Repair, replacement of parts:

When opening the meter, live parts may be exposed. Therefore, the meter must be disconnected from the measuring circuit prior to opening its case for repair or replacement of parts. If repair cannot be avoided unless the meter is opened and live, this work must only be performed by a qualified person who understands the danger involved.

### Faults and abnormal stress:

When it is realised that the safe operation is no longer possible, take the meter out of service and secure it against accidental use.

Safe operation may not be possible,

- when the meter shows obvious signs of damage,
- when the meter no longer functions correctly
- after prolonged storage under adverse conditions,
- due to severe stress during transportation.

## 3. Switching the Clamp meter "ON"

### Battery

We have already fitted your meter with a 9 V flat cell battery according to IEC 6 F 22 or IEC 6 LR 61. It is ready for operation. *Before you use the meter for the first time or after storage, refer to Section "18.1 Maintenance-Battery".*

## Switching the meter "ON"

- Press the "ON/OFF" pushbutton (2).  
Switch-"ON" is acknowledged by a sound signal. As long as you keep the pushbutton pressed, all segments of the liquid crystal display (LCD) will appear. The LCD is shown behind cover page  
After the pushbutton is released, the meter is ready for operation.

### Note:

Electric discharges and high-frequency influence may cause incorrect information to be displayed and block the measuring process. Reset the meter by switching it OFF and ON again otherwise, check the battery connections.

*Disconnect the clamp meter from the measuring circuit before you open it, and see section "18. Maintenance".*

## Automatic TURN-OFF

The meter turns off automatically, when the measured value remains constant (variations of the measured value  $\leq \pm 2$  digits) for about 10 minutes and when neither a pushbutton nor the function selector switch is operated during that time.

## How to prevent automatic TURN-OFF

In order to prevent automatic "TURN OFF" select "CONTINUOUSLY ON" mode. For this, press yellow multi-function pushbutton (5) and the "ON/OFF" pushbutton (2) together. The function "CONTINUOUSLY ON" is shown on the LCD (1) by the symbol  (8).

## Turning the multimeter OFF

Press the "ON/OFF" pushbutton (2).

# 4. Function and range selection

## 4.1 Autoranging

The multimeters feature autoranging for all measuring ranges with the exception of the 30 mV  $\overline{\text{---}}$ , 300 mV  $\overline{\text{---}}$  ranges. Autoranging is Automatically selected after switching the multimeter ON. According to the measured quantity applied, the multimeter automatically selects the measuring range which gives the best resolution. When switching to frequency measurement and ratio measurement the previously selected voltage measuring range is maintained.

The meter switches automatically to :

the next higher range	at	$\pm$	(3099 digits + 1 digit)
the next lower range	at	$\pm$	(240/280 digits - 1 digit)

## 4.2 Manual range section

You can switch OFF autoranging and select the ranges manually according to the table on the following page.

Manual mode is switched OFF when pushbutton AUTO/MAN is pressed (4) for approximately 1s, when the function selector switch (6) is operated, or when the meter is turned OFF and ON again.

When switching back to autoranging from 30 mV  $\overline{\text{---}}$  or 300 mV  $\overline{\text{---}}$  ranges, 3 V  $\overline{\text{---}}$  range is automatically selected.

↓ AUTO/ MAN (4)	Function	Acknowledge		
		Display	Sound Signal	
Short	Manual mode on : Used range is fixed	MAN (10)	1 x	
Short	Switching sequence at: V <sub>m</sub> : 3V → 30V → 300V → 1000V → 30 mV → 300 mV → 3 V → ... V <sub>~</sub> : 3V → 30 V → 300 V → 1000 V → 3V → ... Ω : 30MΩ → 30Ω → 300Ω → 3 kΩ → 30 kΩ → 300kΩ → 3 MΩ → 30MΩ ... F : 30 nF → 300 nF → 3 μF → 30 μF → 30 nF... Hz : 300 Hz → 3 KHz → 30 KHz → 100 KHz → 300 Hz...	MAN (10)	1 x	
	RISH Clamp 1000A			A <sub>~</sub> , A <sub>∞</sub> : 300A → 1000A → 300A ...
	RISH Clamp 300A			A <sub>~</sub> , A <sub>∞</sub> : 30A → 300A → 30A ...
Long	Return to autoranging	-	2 x	

## 5. Liquid crystal display

### 5.1 Digital display

The digital display (9) shows the measured value with correct location of decimal point and sign. The selected measuring Unit (12) and the function (11) are simultaneously displayed. When measuring DC quantities, a minus sign appears in front of the digits, when the positive pole of the measured quantity is applied to the "⊥" input terminal. When upper range limit 3099 ( on the range →▶: 1999), is exceeded then "OL" is displayed. With V and Ω measurements, the digital display is updated two times per second.

### 5.2 Analog indication

The analog indication with pointer presentation gives the dynamic response of a moving-coil movement and is updated 20 times per second, when measuring V and W. Analog indication is of particular advantage when observing variations of measured values and for calibration procedures.

The analog indicator has its own polarity indication. When measuring DC quantities, the analog scale (15) has a negative range of 4 scale divisions so that variations of the measured values around "zero" can be observed exactly. When the measured value exceeds the range of indication, the left triangle (16) is shown before the polarity of the analog indicator switches over after approximately 0.7s. The over range indication on the measuring range (> 3099 digits, on the range →▶ >1999) is shown by the right triangle (13).

### 5.3. Backlit (Optional)

The instrument is provided with user selectable Back-lit for taking measurements in poor lighting conditions / dark areas.

#### Switching the Backlit ON

by pressing "AUTO/MAN" and "HOLD" keys simultaneously the Backlit can be switched ON.

#### Switching the Backlit OFF

by pressing "AUTO/MAN" and "HOLD" keys simultaneously the Backlit can be switched OFF.



## 6. Data "HOLD" facility

The HOLD function allows to automatically hold the measured values.

The meter holds the measured value on the digital display with a sound signal and displays "HOLD" on LCD display (10). The probes or clamp can now be removed from the measuring point and the measured value on the digital display (9) can be read. The analog indication is not influenced by the data HOLD.

The actual measured value can still be noted / read. Note that with a held digital display the location of the decimal point is also held. With autoranging selected, the measuring range of the analog indicator is no longer known.

**Note:** Hold function is not available in functions  $\rightarrow$ ,  $^{\circ}\text{C}$  and 30mV and 300 mV ranges in function  $\vee$  ---.

To activate "HOLD" function momentarily, press the HOLD key.

As long as the data HOLD function is active, manual range selection is not possible. The data HOLD function is switched OFF, when,

- ☛ The "HOLD" pushbutton (3) is pressed for approx. 1s. This is acknowledged by 2 sound signals.
- ☛ The function selector switch (6) is operated or
- ☛ The multimeter is turned OFF and ON again.

## 7. Minimum value and Maximum value "MIN / MAX" storage facility

With the MIN/MAX function, you can hold the minimum and the maximum measured value which was applied to the input of the multimeter after activating MIN/MAX function. The most important application is the determination of the minimum and the maximum value for long-term monitoring of measured quantities. MIN/MAX does not influence the analog indication. The actual measured value can still be noted/read.

Apply the measured quantity to the meter and select the measuring range prior to activating the MIN/MAX function.

With the function activated, you can select the measuring ranges only manually if you switch to another range, the stored MIN/MAX values are cleared.

Function MIN / MAX	↓ DATA MIN / MAX (3)	Meas- uring ranges	Measured Values MIN and MAX	Meter acknowledgement Display		
				Meas. Value digital	MIN MAX	Sound Signal
1. Activate and Store	2 x Short, 30 mV/ 300 mV and °C 1 x short	V $\approx$ A $\sim$ $\Omega$ , F, % °C, Hz	Stored	actual meas- ured value	MIN and MAX flash	1 x
2. Store and display	↓ short	V $\approx$ A $\sim$ $\Omega$ , F, % °C, Hz	Storage Continued in the background, new MIN / MAX. values are displayed	stored MIN value	MIN	1 x
	↓ short			stored MAX value	MAX	1 x
3. Return to 1.	↓ Short ↓	Same as 1.	Same as 1., Stored Values are not cleared	same as 1.	same as 1.	1 x
Reset	Long		Cleared	Cleared	Cleared	2 x

The MIN/MAX function is switched OFF, when the MIN/MAX pushbutton (3) is pressed for approximately 1s, or when the function selector switch (6) is operated, or when the meter is turned OFF and ON again.

## Voltage measurement

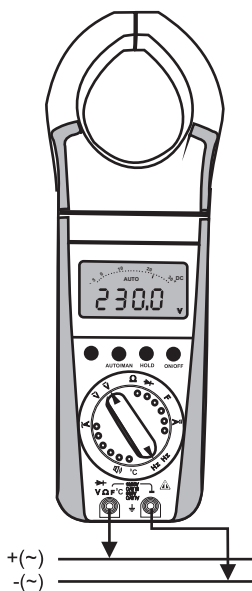

Voltage measurement on electrical systems up to 1000 V

with the KS30 measuring adapter

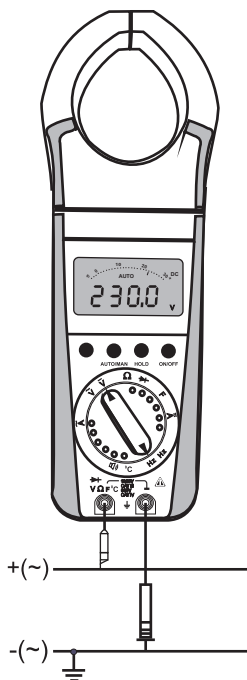

## 8. Voltage measurement

- ☛ According to the voltage to be measured, set the function selector switch (6) to V ~, V ---
- ☛ Connect the test leads as shown. The "⊥" socket should be connected to the lowest potential ground available.

### Notes :

The 30 mV --- and 300 mV --- measuring ranges can only be selected manually with the "AUTO/MAN" pushbutton (4).

On the 1000 V range, an intermittent sound signal warns you, when the measured value exceeds the upper range limit.

### Zero adjustment on the 30 mV --- measuring range

- ☛ Connect the test leads to the meter and join the free ends. After having selected the measuring range, briefly press the yellow multi-function pushbutton (5).

The meter acknowledges zero setting by a sound signal, the LCD shows "00.00" (+ 1 digit) and the decimal point flashes. The displayed voltage at the instant the pushbutton is pressed, is used as reference value (max ± 200 digits) it is automatically deducted from the values measured thereafter.

The zero adjustment is cleared when ;

- ☛ By pressing the yellow multifunction pushbutton (5) for a long time, clearance is acknowledged by the two sound signal.
- ☛ By switching the instrument OFF

### 8.1 Voltage measurement on electrical systems up to 1000V with the KS30 measuring adapter.

On low-voltage systems, transient overvoltages of several kilovolts can occur due to switching functions or lightning discharges. Direct connection of your multimeter to such systems for voltage measurement can be dangerous.

For voltage measurements in power systems with nominal voltages up to 1000V use the KS30 measuring adapter. It is an adapter for multimeter which eliminates dangers caused by overvoltages and incorrect operation of the multimeter. It provides the following protective functions..

- ☛ Protection of the input circuit of voltage measuring range of multimeters. The internal resistance of the KS30 limits the current in the case of overvoltage.
- ☛ Overload capacity : continuously 1200 Vrms  
Transient (rise 10 ms/fall 1000 ms) 6 kV max.
- ☛ Safe suppression of sparking from spark plug after overvoltage.

Voltages above 1000V can be measured with a high-voltage probe, provided the necessary safety precautions are taken !

### Resistance measurement

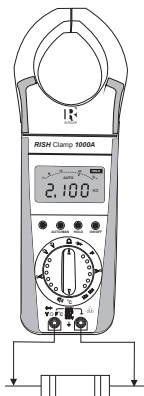

### Diode Test

Forward direction

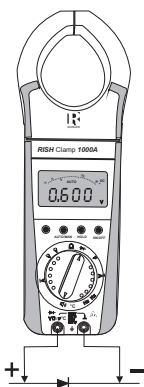

Reverse direction

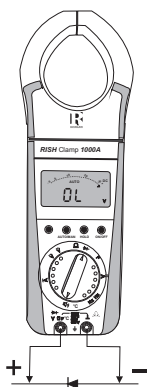

### Continuity Test

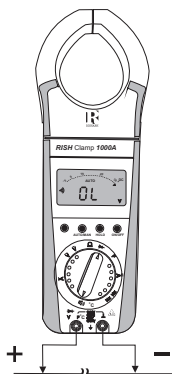
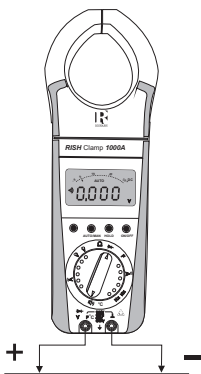

## 9. Resistance measurement

- ☛ Verify that the device under test is electrically dead. External voltages would falsify the measured result !
- ☛ Set the function selector switch (6) to " $\Omega$ ".
- ☛ Connect the device under test as shown.

### Zero adjustment on the 30 $\Omega$ measuring range

When measuring small resistance values on the 30  $\Omega$  range, you can eliminate the resistance of the leads and contact resistance by zero adjustment.

- Connect the test leads to the multimeter and join the free ends.
- Briefly press the yellow multi-function pushbutton (5). The meter acknowledges zero adjustment by a sound signal, the LCD shows "00.00" (+1digit) and the decimal point flashes. The resistance measured at the instant the pushbutton is pressed is used as reference value (max.200 digits) It is automatically deducted from the values measured thereafter. Zero adjustment can be cleared.
- By pressing the yellow multifunction pushbutton (5) for a long time and is acknowledges by two sound signals.
- By switching the multimeter OFF

## 10. Diode test and continuity test

- Verify that the device under test is electrically dead. External voltages would falsify the measured results !
- Set the function selector switch (6) to " $\rightarrow$ "
- connect the device under test as shown.

Forward direction and/or short circuit:

The multimeter displays the forward voltage in Volts. As long as the voltage drop does not exceed the maximum display value of 1.999V you can also rest several series-connected elements or reference diodes with small reference voltage.

Reverse direction or open circuit:

The multimeter indicates overrange "OL"

### Note:

Resistors and semiconductor junction in parallel with the diode falsify the measured results!

### Diode test and continuity test with buzzer

With the "buzzer" function selected, the meter emits a continuous sound signal on the range 0...approx. 0.2 V.

#### To switch the buzzer ON:

- Briefly press the yellow multi-function pushbutton (5).
- The multimeter acknowledges turn-ON with a sound signal. At the same time, the symbol  $\rightarrow$ ) (18) appears on the LCD.

#### To switch the buzzer OFF

- Briefly press the yellow multi-function pushbutton (5) again.
- The multimeter acknowledges turn-OFF with a sound signal. The symbol  $\rightarrow$ ) (18) disappears from the LCD.

When selecting the function "Diode test and Continuity test" with the function Selector switch (6), the buzzer is always switched OFF. Repeated brief pressing of the multifunction pushbutton (5) alternately switches the buzzer on and off. When pressing the push button for a long time, the buzzer is always switched OFF, this is acknowledged by the buzzer sounding twice.

## 11. Temperature measurement

The *Clamp 300A/ 1000A AC-DC* allows you to measure temperature with Pt 100 and Pt 1000 temperature sensors in the range from -200 (-100) °C...+850°C.

- ☛ Set the function selector switch (6) to "Ω"
- ☛ Connect the sensor to the two terminals.
- ☛ Briefly press the yellow multifunction pushbutton (5).  
The multimeter switches to temperature measurement, it automatically detects the connected sensor (Pt 100 to Pt 1000) and shows the measured temperature in °C on the digital display

### Notes:

This measurement automatically considers the lead resistance of Temperature sensors which are available as accessory  
It is not possible to switch over to temperature measurement when the 30Ω resistance range is selected.

### Sensor lead resistance up to 50 Ω

Lead resistance of sensors having a value differing from that of company sensors can be considered up to a value of 50 Ω as follows:

- ☛ Briefly press the yellow multi-function pushbutton (5) again.  
The LCD now displays the resistance value which the multimeter automatically considers after selecting the temperature measuring range. We can recognise that this is the resistance correction value on the temperature measuring range. The " °C " character is simultaneously shown on the display
- ☛ You can set the lead resistance correction value as follows:  
Press the HOLD pushbutton (3) to increment the value, or the AUTO/MAN pushbutton (4) to decrement the value. Each time the pushbutton is briefly pressed, the value changes by one digit.
- ☛ Briefly press the yellow multi-function pushbutton (5) again.  
The LCD displays the measured temperature. The flashing decimal point shows you that we have entered a correction value for the lead resistance. The correction value is retained as long as multimeter is switched on.
- ☛ Each time the yellow multi-function pushbutton (5) is briefly pressed, the display changes between measured temperature and correction value of the lead resistance.

We can exit the temperature measurement function

- by pressing the yellow multi-function switch (5) longer, this is confirmed by the two sound signals.
- by changing the function selector switch.

### Note:

For the lead resistance, the actual value measured on the clamp meter should be taken as correction value and not any specified value.

## 12. Capacitance measurement

- Verify that the device under test is electrically dead. External voltages would falsify the measured results.
- Set the function selector switch (6) to 'F'
- Connect the (discharged!) device under test to the "L" and "F" socket via test lead.

### Notes:

Connect polarized capacitors with the "-" pole to the "L" socket  
Resistors and semiconductor junction in parallel with the capacitor falsify the measured results!

## Zero adjustment on the 30 nF measuring range

When measuring small capacitance values on the 30 nF range, the internal resistance of the multimeter and the capacitance of the leads can be eliminated by zero adjustment.

- Connect the test leads to the meter without device under test.
- Briefly press the yellow multi-function pushbutton (5) displaying "00.00" (+1 digit) on the LCD and by a flashing decimal point. The capacitance measured at the instant the pushbutton is pressed is used as reference value (max.200 digits). It is automatically deduced from the values measured thereafter.

## Zero adjustment can be cleared

- By pressing the yellow multi-function pushbutton (5) for a long time clearance is acknowledged by the two sound signal.
- By switching the multimeter off.

## 13.Frequency measurement

Frequency measurement is possible on all voltage measuring ranges in AC and DC modes.

- Set the function selector switch (6) to  $v\sim$ ,  $v-$
- Connections are made the same way as for voltage measurement.
- Briefly press the yellow multi-function pushbutton (5)  
The multi meter switches to frequency measurement. The frequency is displayed on the LCD.

See section!16. Specifications"for the lowest measurable frequencies and the maximum permissible voltages.

## Changing over between voltage,frequency and duty cycle measurement.

Repeated brief pressing of the yellow multi-function switch (5) changes the measuring function in the following order:

Voltage  $\Leftrightarrow$  Frequency  $\Leftrightarrow$  duty cycle  $\Leftrightarrow$  Voltage

From frequency or duty cycle measurement, directly switching back to voltage measurement is possible.

- By pressing the yellow multi-function pushbutton (5) for a long time. The meter acknowledges this by two sound signals. The voltage measuring range last selected is maintained.
- By operating the function selector switch(6).

## 14. Duty Cycle measurement

With duty cycle measurement, we can determine the ratio of pulse duration to cycle time of recurring square-wave signals.

- Set the function selector switch (6) to  $V\sim$  or  $V-$
- Connections are made in the same way as for voltage measurement  
Briefly press the yellow multifunction pushbutton (5) twice. The meter switches to duty-cycle measurement. The duty cycle that is the percentage pulse duration of a signal is displayed on the LCD in %
- That is:

$$\text{Duty cycle (\%)} = \frac{\text{Pulse duration}}{\text{Cycle duration}} \times 100$$

**Notes :** Input applied frequency must remain constant during the duty cycle measurement. Change-over between voltages,frequency and duty cycle factor measurement is done as described in the preceding section.



## 15. Current measurement

Clamp 1000A can measure current upto 1000 A, in two ranges i.e. 300.0A and 1000 A. Where as Clamp 300A can measure current up to 300 A in two ranges i.e. 30.00A and 300.0 A.

One of the two ranges can be selected manually with AUTO/MAN key. To measure the current through a cable, push the trigger(21) to open the jaws and clamp the jaws around the cable as shown in figure a and figure b.

### 15.1 DC Current measurement

☛ Set the function selector switch(6) to A  $\overline{\text{---}}$ .

#### Zero adjustment on A $\overline{\text{---}}$ functionality

- ☛ Zero adjustment is possible with lower range (30.00A range for Clamp 300A and 300.0A range for Clamp 1000A).
- ☛ Press yellow multifunction key shortly either in AUTO mode or lower range in Manual mode.
- ☛ For higher range (300.0A range for Clamp 300A and 1000A range for Clamp 1000A) same reference which is available for lower range is used.

The meter acknowledges zero setting by a sound signal, the LCD shows "00.00 / 000.0" (+ 1 digit). The displayed current at the instant the pushbutton is pressed, is used as reference value. It is automatically deduced from value measured thereafter. Maximum number of digits that can be nullified are 100.

The zero adjustment is cleared when ;

- ☛ By pressing the yellow multifunction pushbutton (5) for a long time two times.
- ☛ By switching the instrument OFF

### 15.2 AC Current measurement

☛ Set the function selector switch(6) to A  $\sim$  and briefly press multifunction key(5).

#### Chngover between A $\overline{\text{---}}$ and A $\sim$

Repeated brief pressing of the yellow multi-function switch (5) changes the measuring function in the following order:

A  $\overline{\text{---}}$   $\Rightarrow$  A  $\sim$   $\Rightarrow$  A  $\overline{\text{---}}$

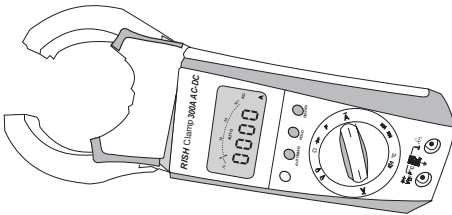

Figure a

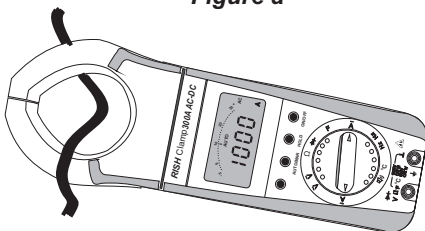

Figure b

## Unique design for safety and comfort

### Rotary mechanism for clamp jaws:

In conventional clamp meters display, keys and clamp jaws are in the same plane. When current measurement is to be done on vertical bus bars, overhead cables, cables in congested places user connects the clamp meter but the keys and display may not be visible, hence not able to take the readings or operate the keys.

To overcome the above mentioned problem Clamp meter 300A/1000A has a unique feature called "Rotary mechanism for clamp jaws". In this, the clamp jaws are rotating. Hence it is possible to align the clamp jaws as the orientation of bus bar/conductor while keeping Display and keys facing the user, so that user can take the readings and operate the keys.

Rotary clamp jaws can be rotated at different angles with the step of  $30^\circ$ , maximum up to  $90^\circ$  in both clockwise as well as anti-clockwise direction as shown in **figure c**.

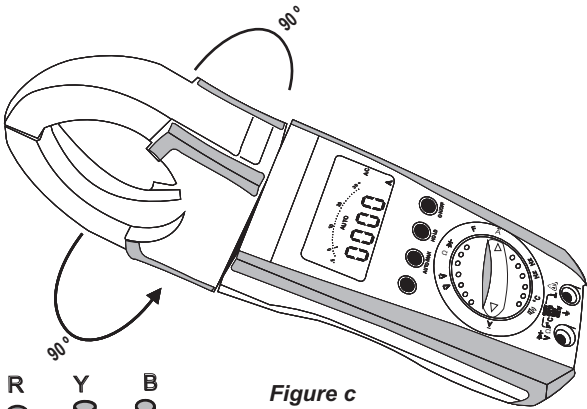

Figure c

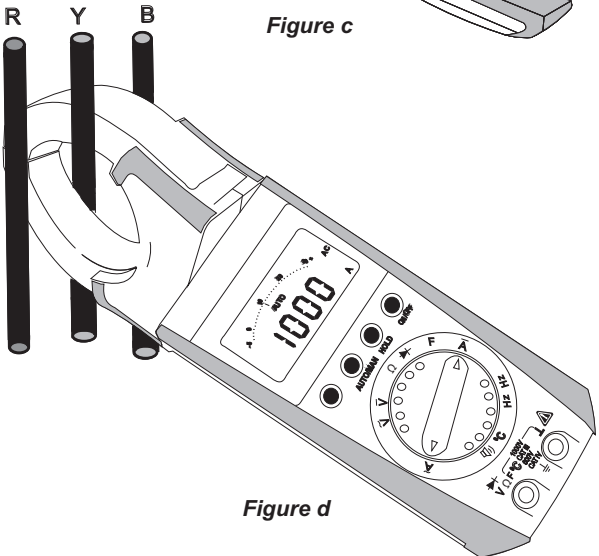

Figure d

Normally, it is difficult to access the middle busbar for current measurement. With "Rotary mechanism for clamp jaws" it is easy to access middle bus bar, while keeping display and keys facing towards the user as shown in **figure d** on previous page.

### Safe trigger mechanism

The conventional clamp meters have trigger mechanism either near to left jaw or right jaw. While taking measurements on bare bus bar or bare conductor the user's hand comes very close to bare bus bar/conductor, which increases the risk of electric shocks to the user.

Also in conventional clamp meters trigger is operated with single finger, usually a thumb which causes fatigue to the user while opening or closing the clamp jaws.

To overcome the above mentioned problems, *RISH Clamp 300A/1000A* has a unique feature called "Safe trigger mechanism" in which trigger is located at bottom side of the clamp meter and far away from the jaws and hence the bus bar.

So user's hand is at safer distance from bare conductors, hence minimizes the risk of electric shock to the user. This is shown in **figure e**.

Also trigger can be comfortably operated with more than one finger which eliminates fatigue to the user.

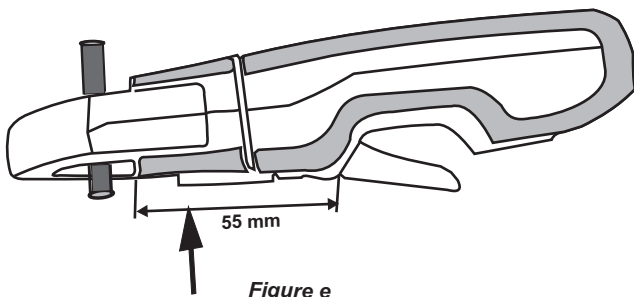

**User's hand is at safer distance from bare bus bar/conductor.**

## 16. Empty Positions

Empty positions on dial indicates no function is available on these positions. The digital display will look like as in figure below. There are three empty positions present on the dial.

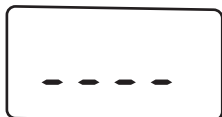

## 17. Specifications

Measurement Function	Measuring Range		Resolution	Input impedance		Intrinsic error of digital display $\pm$ (...% of rdg. + ... digits) at reference conditions	Overload capacity 1)	
							Overload Value	Overload duration
V $\overline{\dots}$	30.00 mV	10 nV	>10 G $\Omega$ // < 40 pF	0.5 + 3 <sup>2)</sup>	1000 V	DC AC eff/rms	Continuously	
	300.0 mV	100 nV	>10 G $\Omega$ // < 40 pF	0.5 + 3				
	3.000 V	1 mV	11 M $\Omega$ // < 40 pF	0.25 + 1				
	30.00 V	10 mV	10 M $\Omega$ // < 40 pF	0.25 + 1				
	300.0 V	100 mV	10 M $\Omega$ // < 40 pF	0.25 + 1				
	1000 V	1 V	10 M $\Omega$ // < 40 pF	0.35 + 1				
V $\sim$ (TRMS)	3.000 V	1mV	11 M $\Omega$ // < 40 pF	0.75 + 2	1000 V	sine wave	10 min	
	30.00 V	10mV	10 M $\Omega$ // < 40 pF	(10...300 Digit)				
	300.0 V	100 mV	10 M $\Omega$ // < 40 pF	0.75 + 1				
	1000 V	1 V	10 M $\Omega$ // < 40 pF	(>300 Digit)				
			No load voltage					
$\Omega$	30.00 $\Omega$	10 m $\Omega$	max. 3.2 V	0.5 + 3 <sup>2)</sup>	1000 V	DC AC eff/rms sine wave	10 min	
	300.0 $\Omega$	100 m $\Omega$	max. 3.2 V	0.5 + 3				
	3.000 k $\Omega$	1 $\Omega$	max. 1.25 V	0.4 + 1				
	30.00 k $\Omega$	10 $\Omega$	max. 1.25 V	0.4 + 1				
	300.0 k $\Omega$	100 $\Omega$	max. 1.25 V	0.4 + 1				
	3.000 M $\Omega$	1 k $\Omega$	max. 1.25 V	0.6 + 1				
	30.00 M $\Omega$	10 k $\Omega$	max. 1.25 V	2.0 + 1				
$\blacktriangleright$	2.000 V	1 mV	max. 3.2 V	0.25 + 1				
A $\sim$ (TRMS)	<i>RISH</i> Clamp1000A	300.0 A	0.1A	-----	1.5 + 5	1100 A	Continuously	
		1000 A	1A	-----	1.5 + 5			
	<i>RISH</i> Clamp300A	30.00 A	0.01A	-----	1.5 + 5			
A $\overline{\dots}$	<i>RISH</i> Clamp1000A	300.0 A	0.1A	-----	1.5 + 5	1100 A	Continuously	
		1000 A	1A	-----	1.5 + 5			
	<i>RISH</i> Clamp300A	30.00 A	0.01A	-----	1.5 + 5			
			Discharge Resistance	U <sub>0 max</sub>				
$^{\circ}$ C	pt 100	-200.0... + 200.0 $^{\circ}$ C	0.1 $^{\circ}$ C	-	-	2 Kelvin + 5 Digit <sup>3)</sup>	1000 V	10 min
		+ 200.0... + 850.0 $^{\circ}$ C	0.1 $^{\circ}$ C	-	-	1.0 + 5 <sup>3)</sup>		
	pt 1000	- 100.0... + 200.0 $^{\circ}$ C	0.1 $^{\circ}$ C	-	-	2 Kelvin + 2 Digit <sup>3)</sup>		
		+ 200.0... + 850.0 $^{\circ}$ C	0.1 $^{\circ}$ C	-	-	1.0 + 2 <sup>3)</sup>		
F	30.00 nF	10 pF	250 k $\Omega$	2.5 V	1.0 + 3 <sup>4)</sup>	1000 V	Continuously	
	300.0 nF	100 pF	250 k $\Omega$	2.5 V	1.0 + 3			
	3.000 $\mu$ F	1 nF	250 k $\Omega$	2.5 V	1.0 + 3			
	30.00 $\mu$ F	10 nF	250 k $\Omega$	2.5 V	3.0 + 3			
Hz	300.0 Hz	0.1 Hz	1 Hz	45 Hz	0.5 + 1 <sup>4)</sup>	1000 V	Continuously	
	3.000 KHz	1 Hz	1 Hz	45 Hz				
	30.00 KHz	10 Hz	10 Hz	45 Hz				
	100.0 KHz	100 Hz	100 Hz	100 Hz				
%	2.0...98.0 %	0.1 %	2 Hz	-	2 Hz...1 KHz $\pm$ 5 digits <sup>5)</sup> 1 KHz...10KHz; $\pm$ 5 Digits/KHz	1000 V		

1) At 0<sup>0</sup>... + 40 $^{\circ}$ C

2) With zero adjustment, without zero adjustment + 35 digits

3) Without sensor

- 4) 3 V  $U_E = 1.5V_{\text{effirms}} \dots 100 V_{\text{effirms}}$   
 30 V  $U_E = 15V_{\text{effirms}} \dots 300 V_{\text{effirms}}$   
 300 V  $U_E = 150 V_{\text{effirms}} \dots 1000 V_{\text{effirms}}$
- 5) On the range 3V $\overline{\sim}$ , Square wave signal positive on one side 5...15 V,  
 F=const., not 163.84 Hz or integral multiple

## Reference conditions

Ambient temperature :	+ 23 °C $\pm$ 2 K
Relative humidity :	45% ... 55 % RH
Frequency of measured quantity	45Hz ... 65 Hz
Waveform of the measured quantity	sinusoidal
Battery voltage	8 V $\pm$ 0.1 V

## Influence Quantities and Variations

Influence quantity	Range of Influence	Measured quantity/ Measuring range	Variation <i>RISH Clamp 1000A/300A</i>
Battery voltage	<sup>1)</sup> $\dots < 7.9 V$ $> 8.1 V \dots 10.0V$	V $\overline{\sim}$	$\pm$ 2 Digit
		V $\sim$	$\pm$ 4 Digit
		30 $\Omega$ / 300 $\Omega$ / °C	$\pm$ 4 Digit
		3 k $\Omega$ ... 30 M $\Omega$	$\pm$ 3 Digit
		A $\sim$	$\pm$ 6 Digit
		F,Hz,%	$\pm$ 10 Digit
Relative humidity	75 % 3 days Meter off	V $\sim$ , A $\sim$ $\Omega$ , F,Hz,% °C	1 x intrinsic error
HOLD	-		$\pm$ 1 Digit
MIN/MAX	-	V $\sim$ , A $\sim$	$\pm$ 2 Digit

1) After the " " symbol is displayed.

Influence quantity	Range of Influence	Measuring ranges	Attenuation
Common mode interference voltage	Noise quantity max. 1000 V $\sim$	V $\overline{\sim}$	> 120 dB
	Noise quantity max. 1000 V $\sim$ 50 Hz, 60 Hz sinusoidal	3V $\sim$ , 30 V $\sim$	> 70 dB
		300 V $\sim$	> 70 dB
		1000 V $\sim$	> 60 dB
Normal mode interference voltage	Noise quantity V $\sim$ value of the measuring range at a time max. 1000 V $\sim$ , 50 Hz, 60 Hz. sinusoidal	V $\overline{\sim}$	> 50 dB
	Noise quantity max. 1000V -	V $\sim$	> 110 dB

Influence quantity	Range of Influence	Measured quantity/ Measuring range	Variation <sup>1)</sup> ± (...% of rdg. + ... digits)
Temperature	0 °C +2 1 °C and +2 5 °C...+4 0 °C	30/300m V ---	1.0+3
		3... 300V ---	0.15+1
		1000 V ---	0.2+1
		V ~	0.4 +2
		30 Ω <sup>2)</sup>	0.15 + 2
		300 Ω	0.25 + 2
		3KΩ - 3MΩ	0.15+1
		30M Ω	1.0+1
		- 200 ... +200°C	0.5°C+2
		+2 00... +8 50°C	0.5+2
		A ---, A ~	± 0.1 x specified accuracy +10
Frequency of the measured quantity	> 65 Hz... 400 Hz	3 ... 300V ~	2.0 + 3
	> 400 Hz... 1 kHz		2.0 + 3
	> 65 Hz... 1 kHz		3.0 + 3
	15 Hz... < 30 Hz	A~	± 1% of range + 1
	30Hz... < 45Hz		
	66 Hz... < 1 kHz		
Wave form of the measured quantity <sup>3)</sup>	Crest factor CF $\frac{1...3}{>3...5}$	V~ <sup>4)</sup> , A~ <sup>4)</sup>	± 1% of rdg. ± 3% of rdg.
	<p>The permissible crest factor CF of the AC quantity to be measured function of the displayed value</p> <p>Voltage measurement                      Current measurement</p>		

- 1) With Temperature : Error data apply per 10K change in temperature  
With Frequency : Error data apply to a display from 300 digits on wards
- 2) With zero adjustment
- 3) With unknown waveform (crest factor CF > 2),measure with manual range selection
- 4) With exception of sinusoidal waveform.

## Display

Liquid crystal display section (52 mm x 38 mm) with analog indication and digital display and with display of the unit of measured quantity function and various special functions.

### Analog :

Indication	LCD scale with pointer
Scale length	55 mm
Graduation	$\mp 5...0... \pm 30$ with 29 scale divisions on $\overline{\text{---}}$ , 0...30 with 25 scale divisions on all other ranges
Polarity indication	with automatic change-over
Overrange indication	by triangle (13)
Sampling rate	20 readings/s, on $\Omega$ ; 10 readings/s

### Digital:

Display/Height of numer.	7-segment numerals/12mm
Number of digits	$3^{3/4}$ digit $\triangleq$ 3100 counts
Overrange	"OL" is displayed.
Polarity indication	"-" sign is displayed, when the positive pole is at " $\perp$ "
Sampling rate	2 readings/s, on $\Omega$ and $^{\circ}\text{C}$ ; 1 reading/s

### Power supply

Battery	9V flat cell battery; manganese-dioxide cell according to IEC 6 F 22, alkaline-manganese cell according to IEC 6 LR 61 or suitable NiCd storage battery
Lifespan	Without backlit ON, using alkaline-manganese cell: approx. 220 hours on $V\overline{\text{---}}$ approx. 80 hours on $V\sim$

Battery test	Automatically flashes the "  p" symbol, when the battery voltage drops below approx. 7 V
--------------	---

### Electrical Safety:

As per IEC 61010-1 : 2010-06

Protection class	:	II
Measuring Category	:	III IV 1000V 600V
Pollution Degree	:	2
Test Voltage	:	7.4 kV ~ between housing and input 4.26 kV ~ between housing with jaws and input

### EMC

	Electromagnetic compatibility
Emission	EN 61326 : 2002 Class B
Immunity	EN 61326 : 2002 IEC 61000-4-2 8 kV atmosphere discharge 4 kV contact discharge IEC 61000-4-3 3 V/m

## Response time (after manual range selection)

Measured quantity/ measuring range	Response time		Transient response for step function of the measured quantity
	of analog indication	of digital display	
V $\dots$ , V $\sim$ A $\dots$ , A $\sim$	0.7 s	1.5 s	from 0 to 80 % of upper range limit
30 $\Omega$ ... 3 M $\Omega$	1.5 s	2 s	from $\infty$ to 50 % of upper range limit
30 M $\Omega$	4s	5 s	
$\rightarrow$	0.7 s	1.5 s	
$\mu$ F, $^{\circ}$ C		Max. 1...3 s	from 0 to 50 % of upper range limit
300 Hz, 3 KHz		Max. 2 s	
30, 100 KHz		Max. 0.7 s	
% (1Hz)		Max. 9 s	
% ( $\geq$ 1Hz)		Max. 2.5 s	

### Ambient conditions

Functional temperature

range -10 C...+50 C

Storage temperature

Range -25<sup>0</sup> C...+70<sup>0</sup> C without batteries

Altitude up to 2000 m

### Mechanical configuration

Dimensions 90mm(W) x 270 mm(L) x 70 mm(H)

Weight 600 g approx., including battery

## 18. Maintenance

### Caution

*Disconnect the meter from the measuring circuit before you open it to replace the battery !*

### 18.1. Battery

Prior to initial start-up, or after storage of clampmeter, verify that the battery of clamp meter does not leak. Repeat this check in regular short intervals. If the battery leaks, completely remove the battery electrolyte carefully with a moist cloth and install a new battery before you operate clamp meter again.

When the symbol " (17) flashes on the LCD (1) replace the battery as soon as possible. Measurement can be done, but a reduced measuring accuracy must be taken into account.

The multimeter operates with a 9 V flat cell battery according to IEC 6 F 22 or IEC6 LR6 1 or with a suitable NiCd storage battery.





### **Attention !**

Disconnect the instrument from the measuring circuit before opening battery cover to replace the batteries.

#### **Replacing the battery**

- Place the clamp meter on its face. Loosen the screw of battery cover Which is at rear bottom side of meter. Remove battery cover by Sliding it to bottom side.
- Remove the battery from the battery compartment and carefully disconnect battery connectors.
- Snap the battery connectors to a new 9 V battery and insert the battery into the battery compartment.
- Replace the battery cover by fitting it into slots on battery compartment
- Tighten the battery cover with the screw.  
Please destroy the batteries in an environment friendly way.

#### **18.2. Periodic Check-up:**

The clamp meter does not require any specific maintenance. The surface between opening jaws should be cleaned with dry cloth before operating. Avoid use of cleansers, abrasives or solvents.

#### **19. Servicing**

When you need service, refer the cover page for company address.

NOTE



---

## **Rishabh Instruments Limited**

F-31, M.I.D.C., Satpur,  
Nashik - 422 007  
Maharashtra, India

Telephone : (0253) 2202202, 2202162

Fax : (0253) 2351064, 2202303

E-mail : [service@rishabh.co.in](mailto:service@rishabh.co.in)

Website : [www.rishabh.co.in](http://www.rishabh.co.in)